

Instruction Manual

BODY COMPOSITION ANALYZER

DC-360

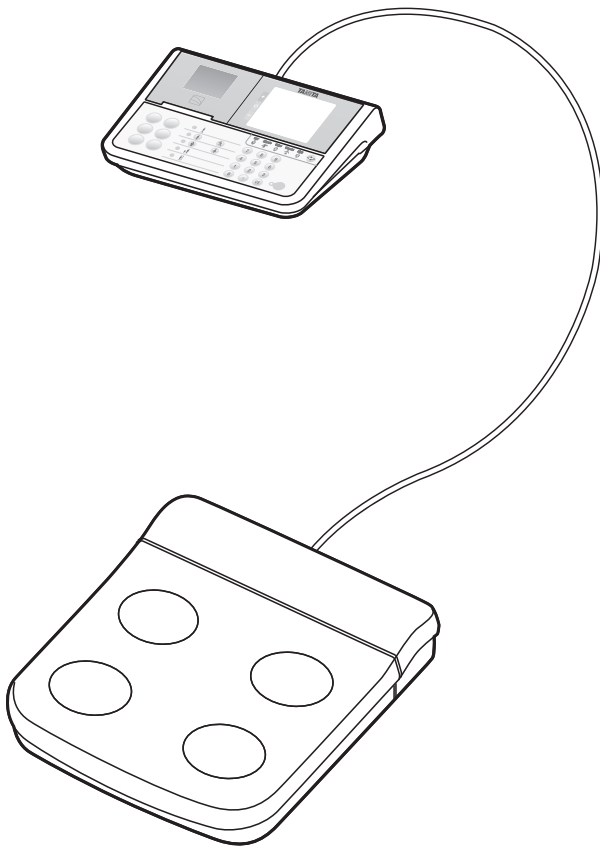

REMOTE DISPLAY VERSION

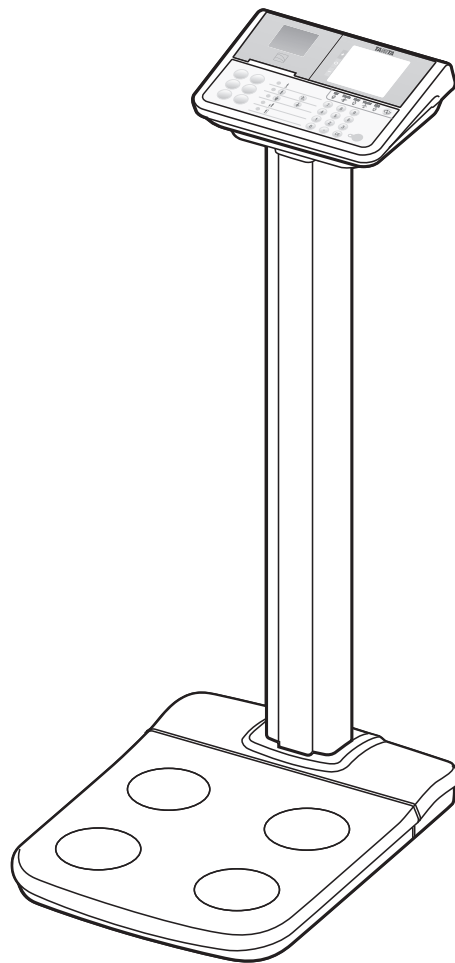

COLUMN MOUNTED VERSION



Please read this Instruction Manual carefully and keep it for future reference.

Contents

Before Use

For Your Safety4
Part names & Connection Procedure8
Setting the Printer Paper / Setting an SD Card10
Power Supply12
Settings13

How to Use

Taking a Measurement.....15
 Body Composition Mode..... 15
 Measurement Results 17
 Scale Mode 19
Various Criteria20
 What is body fat percentage?..... 20
 What is total body water percentage? 21
 What is visceral fat rating?..... 21
 What is basal metabolic rate (BMR)? 22
 What is metabolic age? 22
 What is muscle mass? 23
 What is physique rating? 23
 What is bone mass?..... 24
Output and Storage of Measurement Results25

If Necessary

Troubleshooting31
Technical Notes32
**The Regression Formula for
Basal Metabolic Rate (BMR)36**
Specifications38

For Your Safety

en

Before Use

This section explains precautionary measures to be taken to avoid injury to the users of this device and others, and to prevent damage to property. Please familiarize yourself with this information to ensure safe operation of this equipment.

Warning

Failure to follow instructions highlighted with this mark could result in death or severe injury.

Caution

Failure to follow instructions highlighted with this mark could result in injury or damage to property.



This mark indicates actions that are prohibited.



This mark indicates instructions that must always be followed.

Warning

This equipment must not be used on subjects with pacemakers or other mechanical implants.

This equipment passes a weak electrical current through the body which could interfere with and cause the malfunction of electrical medical implants, resulting in serious harm.



Do not handle the plug with wet hands.

This may result in electric shock, fire, or leakage.



Prohibited

Keep this equipment away from flammable gas and oxygen-rich environments.

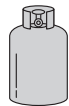

Do not modify this equipment in any way.

This can cause electric shock or injury, or affect the accuracy of analysis.



Do not use a multi-plug adapter.

This may cause fire.

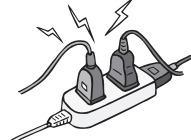

Caution



Prohibited

Keep away from water.

Avoid using on subjects with metal allergies.

Allergic reactions may be caused by the stainless steel used in the electrodes of this device.

Do not jump on the equipment.

Do not lean on the equipment.

Do not use this equipment near other products that emit electromagnetic waves.

Do not insert fingers into gaps or holes.

Do not apply force to the display.

The screen panel may break and cause injury.

Assist persons with disabilities or children under 15 years old.

A person who is familiar with the device should assist persons with disabilities or children under 15 years old who may not be able to take measurements alone.



Always...

Clean the scale platform with appropriate disinfectant after each use.

Stand clear of the subject during measurement to ensure accuracy.

Continually monitor both the subject and the equipment for anomalies.

If an anomaly in the subject or equipment is discovered, take appropriate action, such as stopping the equipment, while ensuring the safety of the subject.

Use the included AC adapter.

Do not lean against the equipment.

Unplug the AC cord from the equipment when moving it.

Tighten the adjustable feet when moving the equipment.

Interpretation of analysis results (e.g. evaluation of measurements and formulation of exercise programs based on results) must be performed by a professional.

Weight loss measures and exercise based on self-analysis could be harmful to your health. Always follow the advice of a qualified professional.

For Accurate Measurements

Avoid measuring after strenuous exercise.

This may cause inaccurate measurements. Please take measurements after sufficient rest.



Avoid measuring after excessive food or fluid intake or when dehydrated.

This may cause inaccurate measurements. For greater accuracy, avoid using directly after waking up. Use at the same time on each occasion, at least three hours after a meal.



Ensure inner thighs are not touching each other during measurement. If necessary, place a dry towel between thighs.

Do not take measurements while using transmitting devices, such as mobile phones, which may affect readings.

Use the equipment under the same conditions and in the same position as much as possible for accurate tracking of changes.

Readings are affected by the level of hydration and position of the body. Please use at the same time of day each time, under the same conditions and in the same body position.



Avoid measuring in multiple locations with greatly differing temperatures.

This may cause inaccurate measurements. Allow the equipment to stand for at least 2 hours before using if it is moved to a new location with a temperature difference of 20°C or more.



Make sure the soles of feet are free of excess dirt, as this may block the mild electric current.

Bare feet should be placed correctly on the electrode platform. Place arms straight down during measurement.

Use in a stable location.

Errors in measurements may occur if the device is used in an unstable location.

Do not wipe the equipment with corrosive chemicals (gasoline, cleaner, etc.). Please use a neutral detergent to clean the equipment.

Scheduled Maintenance

TANITA recommends that each facility conduct periodic checks of each unit.

1. Check the following at least daily:
 - The unit is on a stable and level surface on a firm flooring, not on a thick carpet
 - Date and time settings
2. Visually inspect the following at least weekly:
 - The display for any damage or contamination
 - All cables, cords, and connector ends for damage or contamination
 - All safety-related labeling for legibility
 - All accessories (electrodes, etc.) for wear or damage
3. Visually inspect the following at least monthly:
 - Mounting screws on stand

Update settings, replace items, or call for service as necessary according to the results of the visual inspections. Do not use the unit if you see any signs of damage. Equipment that has been damaged must be checked for proper operation by qualified personnel before using again.

Part names & Connection Procedure

en

Before Use

Remote display version

Column mounted version

Control Box

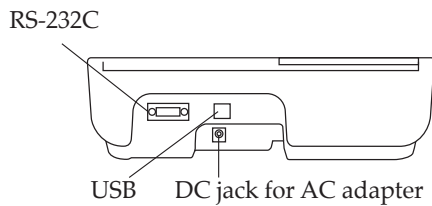
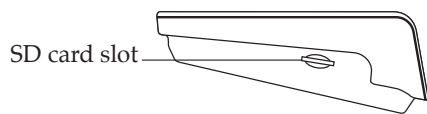
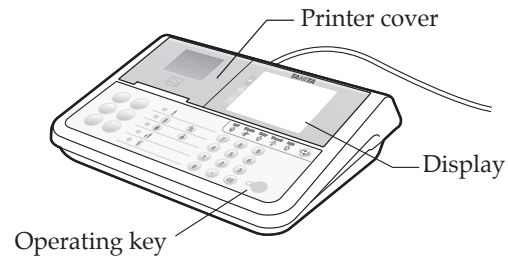

*RS-232C and USB are mutually exclusive.

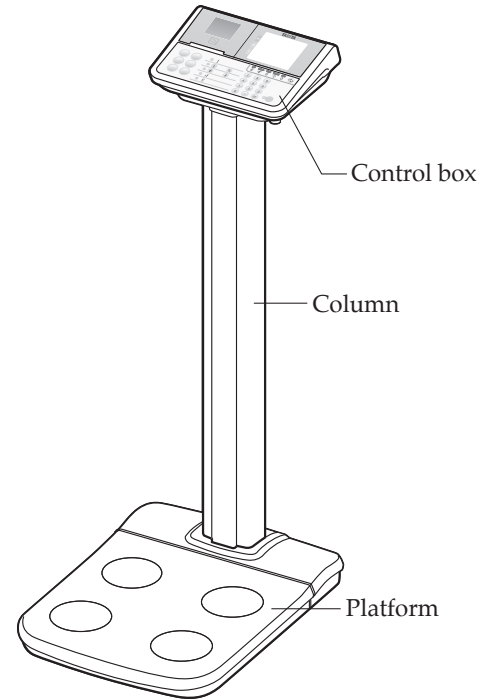

Platform

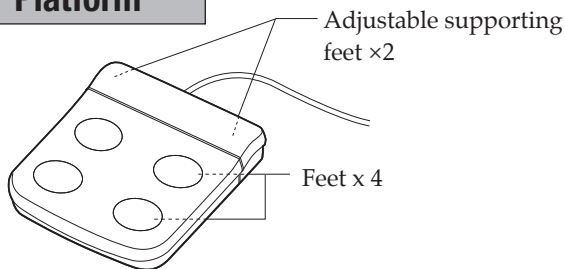

Connecting to the Power Supply

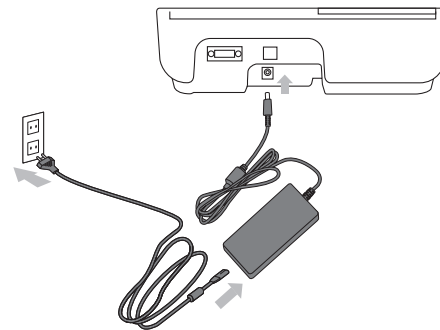

Symbols and their Meanings

	Positive polarity		Serial number
	Alternating current		Direct current
	Input, Output		WEEE - Waste Electrical and Electronic Equipment Directives
	Caution Refer to the attached notes.		For indoor use only
	SD card		See the instructions
	Serial interface		Manufacturer

*The SD logo is a registered trademark of the SD Association.

Accessories

- This manual
- AC adapter



- AC cord



- Printer paper



Display and Keys

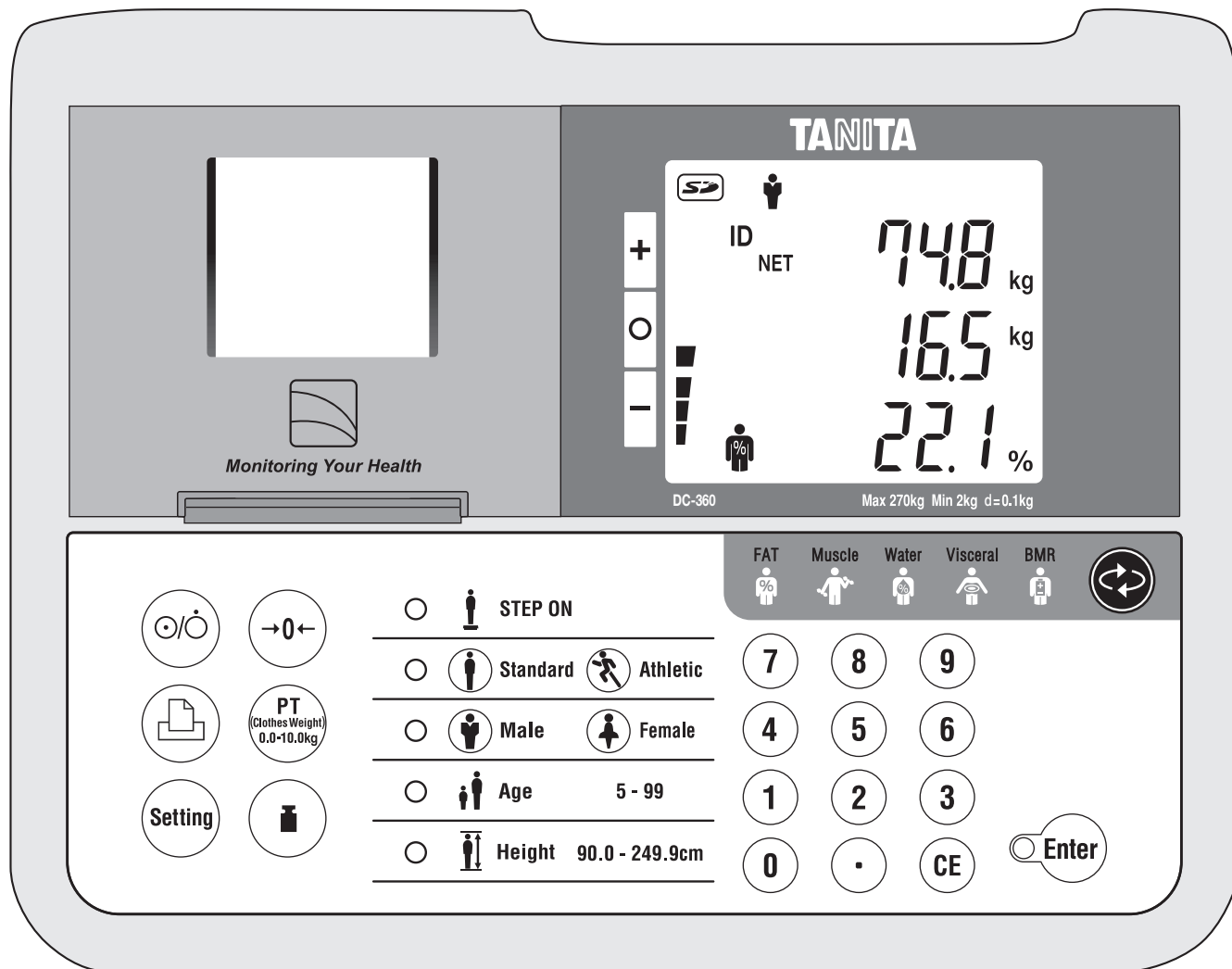

Meanings of the LED Indicators and Keys

	Turn ON / OFF the power
	Feeds the printer paper
Setting	Set various functions
	Reset zero point
PT (Clothes Weight) 0.0-10.0kg	Set preset value (Clothes weight)
	Select measurement mode
	Select measurement display

FAT 	Display Body Fat (percentage and mass) *Not measured value but calculated value		
Muscle 	Display Body Muscle (percentage and mass) *Not measured value but calculated value		
Water 	Display Body Water (percentage and mass) *Not measured value but calculated value		
Visceral 	Display Visceral Fat Rating	BMR 	Display Basal Metabolic Rate
	Indicate to step on		
	Select the body type from "Standard mode" or "Athletic mode"		
	Select the gender from "Male" or "Female"		
5 to 99	Enter the age between "5 to 99 years"		
90.0 to 249.9cm	Enter the height between "90.0cm to 249.9cm"		
	Confirms the entered numerical value.		

Setting the Printer Paper / Setting an SD Card/Positioning the Scale

en

Before Use

Setting the Printer Paper

- 1** (1) Turn the power OFF and push the handle on the left hand side of the controller.
(2) Open the printer cover.
(3) Set the printer paper in place.
Peel off the adhesive and pull out approximately 10cm of paper from the printer paper.
(4) Replace the printer cover to its original place.

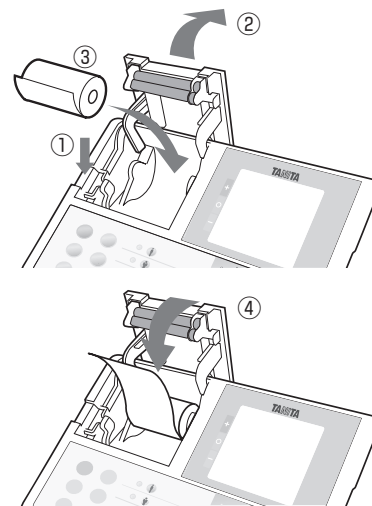

- 2** Press  to turn on the device.

After all the indicators are displayed,  is displayed.

If the device is turned on with the printer cover open,  is displayed.

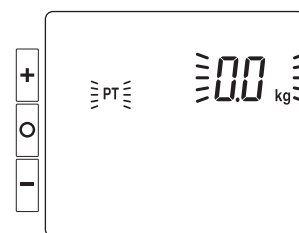

- 3** Press . The printer paper is cut automatically, and the settings are completed.

Paper is not automatically cut when 'Auto Cut' is set to 'Off'.

Note

Cutting automatically setting → See P.13 setting4

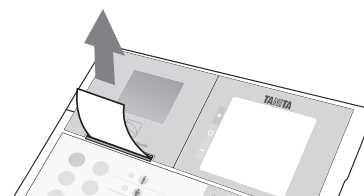

Setting an SD Card

- 1 When the power is turned OFF, insert an SD card into the slot with the logo side facing upwards.

Make sure the card is facing in the correct direction when inserting it.



- 2 Press  to turn on the device.

- 3 When the device detects the SD card, the mark on the right appears in the upper left corner of the screen.

Be sure to insert and remove the SD card when the device power is off to avoid damaging the SD card.

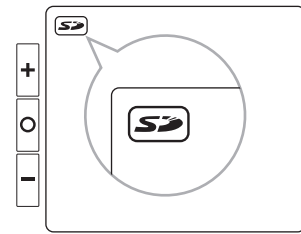

Note

Compatible with SD and SDHC memory cards
Not compatible with SDXC memory cards

Positioning the Scale

To obtain the highest level of accuracy, please make sure that all four (4) feet are touching the floor evenly.

For further accuracy and security, position the two adjustable supporting feet until they just make contact with the floor (do not overextend).

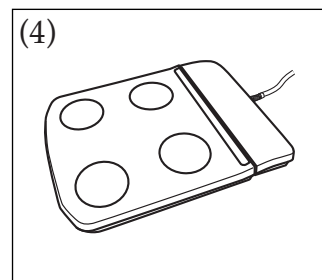
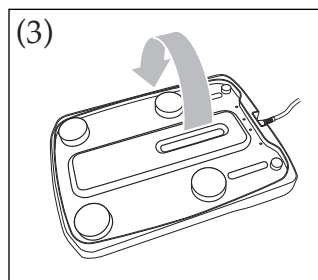
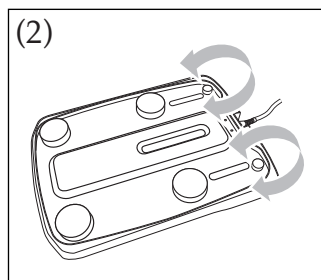
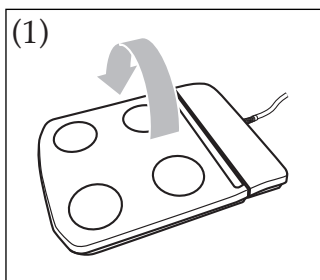

Power Supply

en

Before Use

Turning the Main Power ON/OFF

Turning the main power ON.

Press the  key to turn on the power.

The initial screen is displayed.



Turning the main power OFF.

Press the  key to turn on the poweroff.

Emergency Shut Down

Keep the area around the plug socket clear during operation of the equipment in case of an emergency.

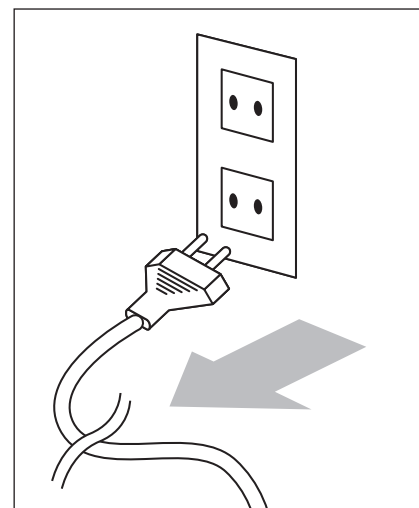

Settings

en

Before Use

- 1 Press the  key to change the mode.
The setting screen is displayed.



Note

- The  key cannot be used when the scale is measuring weight or results are displayed while standing on the platform after measurement.

- 2 Select the setting item from the list below.
Enter numerical values and Press the  key.

Setting item List  → Save changes and return

 → Correct input number or cancel

0	Check the software version	11	Automatic determination time of input information (0-9 second(s)) (Default: 0) * 0: Disables this function
1	Date and time * Date and time → *See Note below	18	Target body fat ratio input (0: off 1: on) (Default: 0)
2	Number to be printed automatically (0-3 sheet(s)) (Default: 1)	19	Printout language (1: English, 2: French, 3: German, 4: Spanish, 5: Italy, 6: Turkey) (Default: 1)
4	Cutting automatically (0: off 1: on) (Default: 1)	20	Printout contents (1: full 2: short) (Default: 1)
5	Beep sound (0: off 1: on) (Default: 1)	21	Timeout function of result display (0: disable 1: enable) (Default: 0)
7	ID number (Automatic count up) (0: off 1: on) (Default: 0)	23	BMR kJ unit display ON/OFF (0: off 1: on) (Default: 1)
8	Measurement flow (0: off Two step flow / Measure body weight first 1: on One step flow / Enter personal info first) (Default: 0) * Measurement flow → See P.15	45-67	Printing item settings (0: off 1: on) → See P.26
9	Body type selection (Athletic mode) (0: off 1: on) (Default: 1) * Athletic mode → See P.15&P.30	80	SD Card mode (0: off 1: on) → See P.29
10	Height input unit (0: off 0.1cm increments 1: on 1cm increments) (Default: 0)		

Note

Enter the year, month, day, hour and minute.
The date format is "yyyy mm dd hh:mm"
(Date input range: 2015 01 01 00:00 to 2099 12 31 23:59)

Example 3:45 pm, 10th April, 2015
"2015" "04 10" "15:45"

To enter a number with 1 digit (0 to 9), press "0" first.

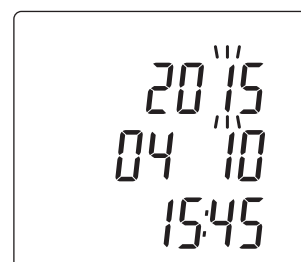

Settings (continued)

en

Before Use

Select the Measurement Mode

Select the measurement mode by pressing the  key.

The measurement mode is switched in the following order when the  key is pressed:

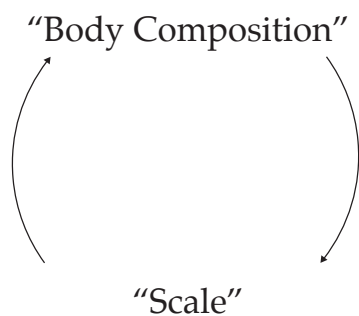

The “” mark is displayed when the scale mode is selected.

Body Composition Mode

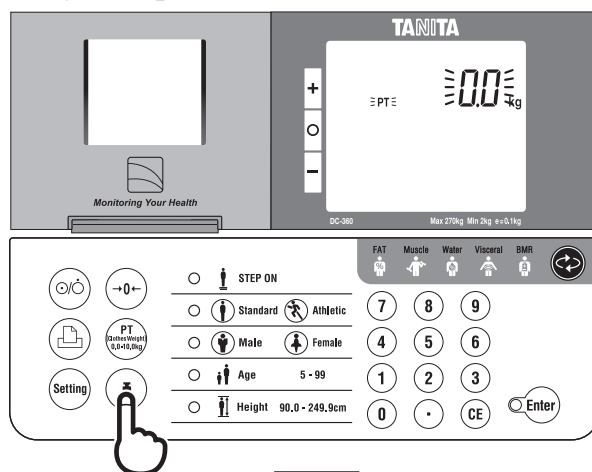

Scale Mode

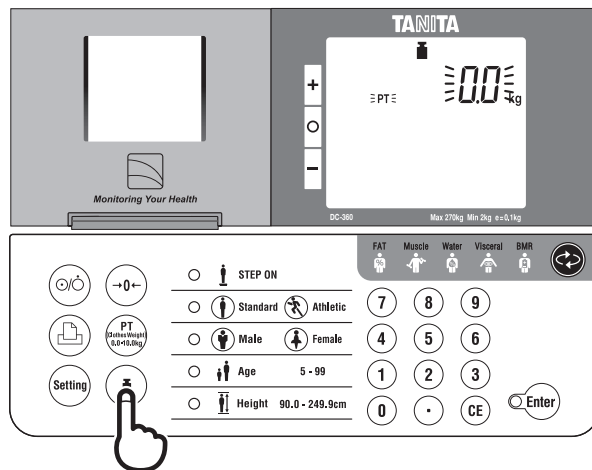

Taking a Measurement

en

Body Composition Mode (Two step flow Measure body weight first)

How to Use

1 Enter the preset tare value (clothes weight)

Turn the power on, and check that the "PT" mark is displayed.
Enter the preset tare value (clothes weight)
The tare value range is 0.0 to 10.0kg

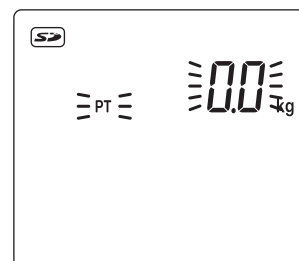

2 Enter ID number

If the ID number function is set to OFF, the scale switches directly to "Measure body weight" without requesting an ID number.
If the ID number is set to ON, ID number will be increased automatically.
To change ID number manually, press CE and enter the preferred ID number.
The ID number range: 0 to 9999999999999999

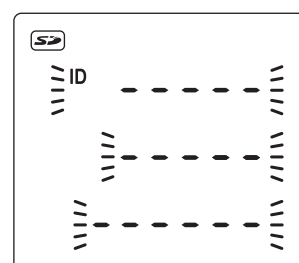

Note ID number setting → See P.13 setting 7

3 Measure body weight

Step onto the platform with bare feet, after "STEP on" flashes.
"NET" is displayed when you have entered a tare value (clothes weight).
The "Stabilised" icon (●) appears when the load is stable.

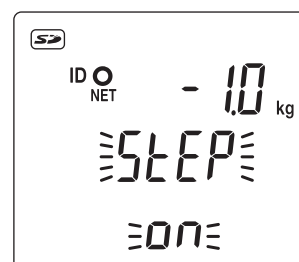

Note

When the One step flow is selected, enter personal information first.
→ See P.13 Setting 8

If the scale does not detect a load, press PT (Clothes Weight 0.0-10.0kg) to switch to "Input tare value".
If the scale detects the load, press PT (Clothes Weight 0.0-10.0kg) to display the entered tare value.

4 Select body type Standard Athletic

If the body type selection (Athletic mode) is set to OFF, the scale switches directly to "Select gender" without requesting a body type.
The "A" mark is displayed when the Athletic mode is selected.

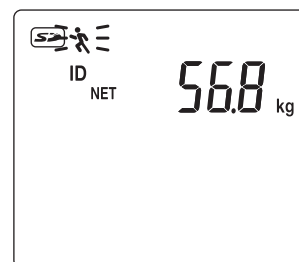

Note Athletic mode setting → See P.13 Setting 9
Athlete condition → See P.30

Taking a Measurement (continued)

en

How to Use

Body Composition Mode

5 Select gender  Male  Female

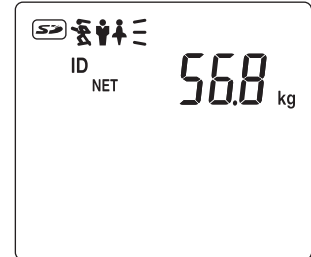

6 Enter age  Age

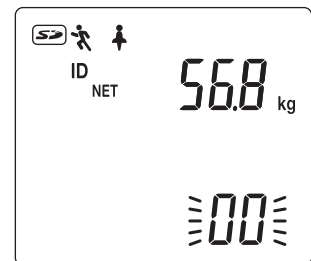
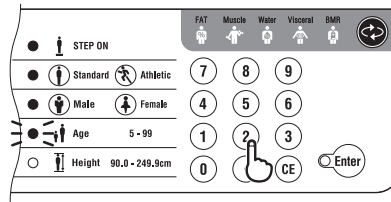

The age range: 5 to 99

7 Enter height  Height

The height range:
90.0 to 249.9cm

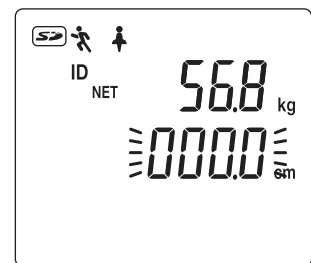
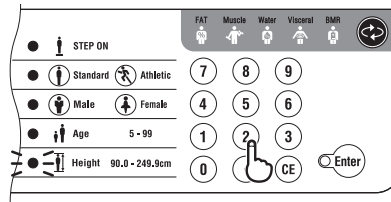

Note Height input unit setting → See P.13 setting 10

8 Set target body fat ratio

If the target body fat ratio function is set to OFF, the scale switches directly to “Measuring impedance” without entering the target value.

The body fat ratio range: 4 to 55 %

Note Target Body Fat ratio input → See P.13 setting 18

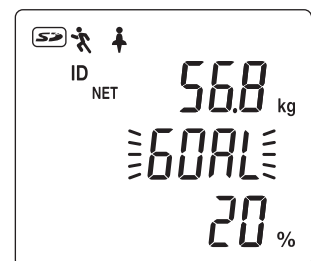

9 Measuring body composition

The scale starts measuring impedance after you have entered all of the personal information.

Wait until “StAY” is displayed, and remain standing while measuring.

The measurement is complete when all “ooooo” disappear.

The scale displays the measurement results after measuring the whole body impedance.

The next measuring starts by pressing .

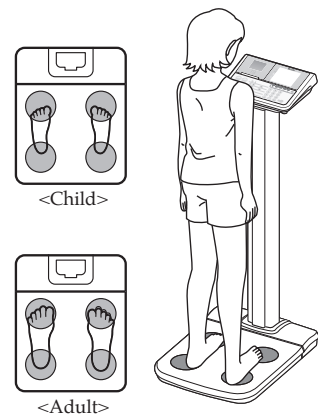

Measurement Results

Output Measurement Results (Body Composition Mode)

The measurement results are displayed on the LCD after measurement is completed.

The results are output to the PC immediately after measurement is completed.

Press the  key to select the measurement display.

The measurement display is switched in the following order by pressing the  key.

→ "Fat" → "Muscle" → "Body Water" → "Visceral fat rating" → "Basal metabolic rate" → "BMI"

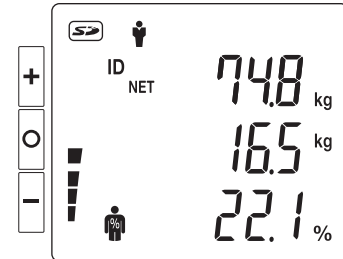

Body Fat (Applicable age: 5 to 99)

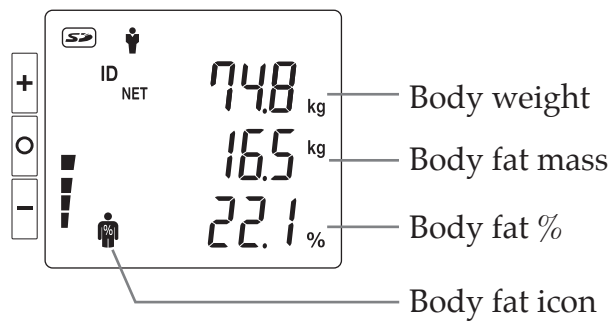

Muscle (Applicable age: 5 to 99)

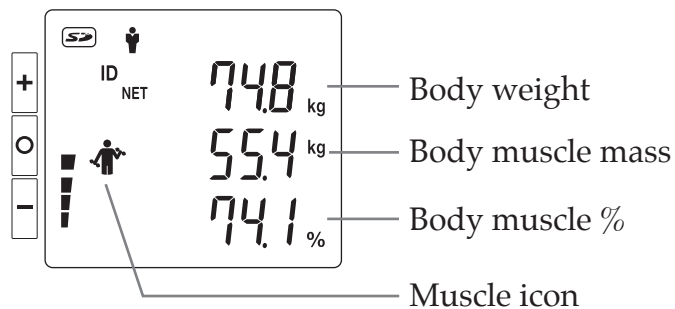

*Muscle mass level compared to the general population.

Taking a Measurement (continued)

en

How to Use

Measurement Results

 **Total Body water** (Applicable age: 5 to 99)

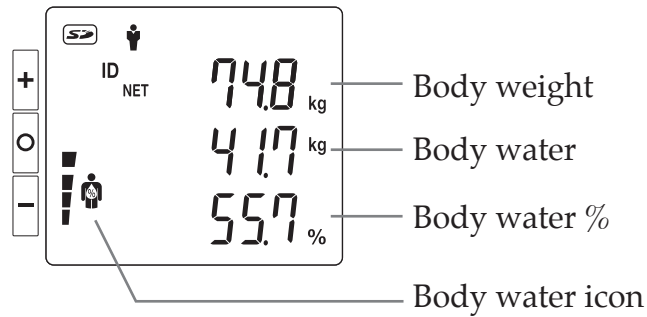

 **Visceral fat rating** (Applicable age: 18 to 99)

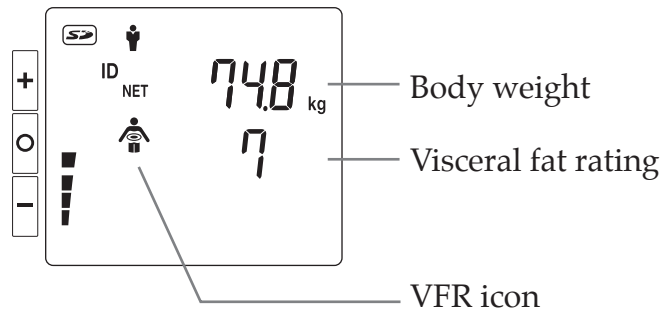

 **Basal metabolic rate** (Applicable age: 18 to 99)

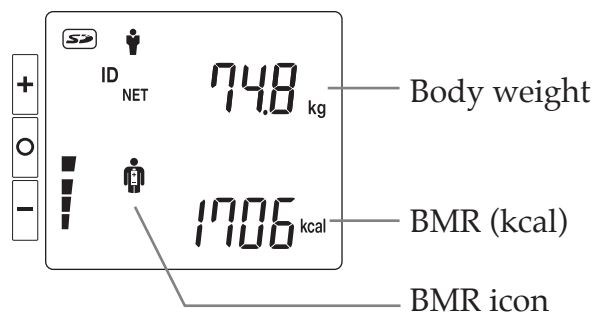

*Basal metabolic rate level compared to the general population.

Note BMR kJ unit display ON/OFF setting → See P.13 setting 23

Body Mass Index (BMI) (Applicable age: 5 to 99)

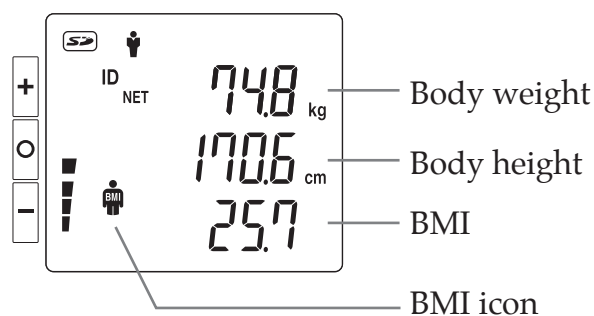

Scale Mode

The “**T**” icon is displayed when the scale mode is selected.

1 Enter the ID number

If the ID number function is set to OFF, the scale starts measuring weight immediately.

If the ID number is set to ON, ID number will be increased automatically.

To change ID number manually, press **CE** and enter the preferred ID number.

The ID number range is from 0 to 9999999999999999.

Press **PT** (0.0-10.0kg) to enter tare value (clothes weight).

The tare value range is 0.0 to 10.0kg.

Note ID number setting → See P.13 setting 7

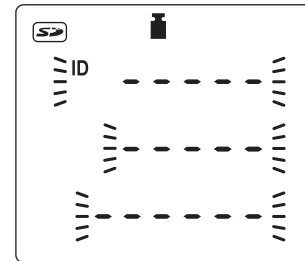

2 Measure body weight

Step onto the platform, after “**StEP on**” flashes.

“**NET**” is displayed when you have entered a tare value (clothes weight).

The “**Stabilized**” icon (●) appears when the load is stable.

The “**Stabilized**” icon (●) disappears when the load is unstable.

When the load is stable, the measurement results are output via the USB port and stored on an SD card.

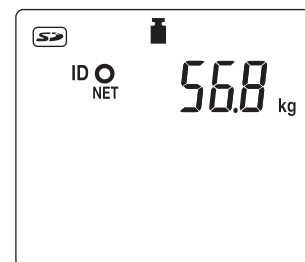

- What is total body water percentage? (Applicable age 5 to 99)

Total Body Water Percentage is the total amount of fluid in a person's body expressed as a percentage of their total weight.

Water plays a vital role in many of the body's processes and is found in every cell, tissue and organ. Maintaining a healthy total body water percentage will ensure the body functions efficiently and will reduce the risk of developing associated health problems.

Your body water levels naturally fluctuate throughout the day and night. Your body tends to be dehydrated after a long night and there are differences in fluid distribution between day and night. Eating large meals, drinking alcohol, menstruation, illness, exercising, and bathing may cause variations in your hydration levels.

Your body water percentage reading should act as a guide and should not be used to specifically determine your absolute recommended total body water percentage. It is important to look for long-term changes in total body water percentage and maintain a consistent, healthy total body water percentage.

Drinking a large quantity of water in one sitting will not instantly change your water level. In fact, it will increase your body fat reading due to the additional weight gain. Please monitor all readings over time to track the relative change.

Every individual varies but as a guide the average total body water percentage ranges for a healthy adult are:

Female: 45 to 60%

Male: 50 to 65%

Source: Based on Tanita's Internal Research

Note: The total body water percentage will tend to decrease as the percentage of body fat increases. A person with a high percentage of body fat may fall below the average body water percentage. As you lose body fat the total body water percentage should gradually move towards the typical range given above.

- What is visceral fat rating? (Applicable age 18 to 99)

This feature indicates the rating of visceral fat in your body.

Visceral fat is the fat that is in the internal abdominal cavity, surrounding the vital organs in the trunk (abdominal) area. Research shows that even if your weight and body fat remains constant, as you get older the distribution of fat changes and is more likely to shift to the trunk area especially post menopause. Ensuring you have healthy levels of visceral fat may reduce the risk of certain diseases such as heart disease, high blood pressure, and the onset of type 2 diabetes.

The Tanita Body Composition Analyzer will provide you with a visceral fat rating from 1 to 59.

Rating from 1 to 12

Indicates you have a healthy level of visceral fat. Continue monitoring your rating to ensure that it stays within the healthy range.

Rating from 13 to 59

Indicates you have an excess level of visceral fat. Consider making changes in your lifestyle possibly through diet changes or increasing exercise.

Source: 1) Tanita Institute Contract Study. Algorithm Development for Estimating Visceral Fat Rating. SB Heymsfield MD. Columbia University College of Physicians and Surgeons 2004.

2) Wang, Z., et al. Japanese-American Differences in Visceral Adiposity and a Simplified Estimation Method for Visceral Adipose Tissue. North American Association for the Study of Obesity. Annual Meeting. Abstract 518-P. 2004

Note:

- Even if you have a low body fat rate, you may have a high visceral fat level.
- For medical diagnosis, consult a physician.

Various Criteria (continued)

en

How to Use

- What is basal metabolic rate (BMR)? (Applicable age 18 to 99)

What is BMR?

Your Basal Metabolic Rate (BMR) is the minimum level of energy your body needs when at rest to function effectively including your respiratory and circulatory organs, neural system, liver, kidneys, and other organs. You burn calories when sleeping.

About 70% of calories consumed every day are used for your basal metabolism. In addition, energy is used when doing any kind of activity however; the more vigorous the activity is the more calories are burned. This is because skeletal muscle (which accounts for approximately 40% of your body weight) acts as your metabolic engine and uses a large amount of energy. Your basal metabolism is greatly affected by the quantity of muscles you have, therefore increasing your muscle mass will help increase your basal metabolism.

By studying healthy individuals, scientists have found that as people age, their metabolic rate changes. Basal metabolism rises as a child matures. After a peak at the age of 16 or 17, it typically starts to decrease gradually.

Having a higher basal metabolism will increase the number of calories used and help to decrease the amount of body fat. A low basal metabolic rate will make it harder to lose body fat and overall weight.

How does a Tanita body composition analyzer calculate BMR?

The basic way of calculating Basal Metabolic Rate (BMR) is a standard equation using weight and age. Tanita has conducted in-depth research into the relationship of BMR and body composition giving a much more accurate and personalized reading for the user based on the impedance measurement. This method has been medically validated using indirect calorimetry (measuring the breath composition).*

* Reliability on equation for Basal Metabolic Rate: At 2002 Nutrition Week: A Scientific and Clinical Forum and Exposition
Title: International Comparison: Resting Energy Expenditure Prediction Models: The American Journal of Clinical Nutrition

- What is metabolic age? (Applicable age 18 to 99)

This feature calculates your BMR and indicates the average age associated with that type of metabolism.

If your BMR Age is higher than your actual age, it is an indication that you need to improve your metabolic rate.

Increased exercise will build healthy muscle tissue, which will improve your metabolic age.

You will obtain a reading between 12 and 90. Under 12 will be displayed as "12" and over 90 displayed as "90".

- What is muscle mass? (Applicable age 5 to 99)

This feature indicates the weight of muscle in your body.

The muscle mass displayed includes the skeletal muscles, smooth muscles (such as cardiac and digestive muscles) and the water contained in these muscles.

Muscles play an important role as they act as an engine in consuming energy. As your muscle mass increase, your energy consumption increases helping you reduce excess body fat levels and lose weight in a healthy way.

- What is physique rating? (Applicable age 18 to 99)

This feature assesses your physique according to the ratio of body fat and muscle mass in your body.

As you become more active and reduce the amount of body fat, your physique rating will also change accordingly. Even though your weight may not change, your muscle mass and body fat levels may be changing making you healthier and at lower risk of certain diseases.

Each person should set their own goal of which physique they would like and follow a diet and fitness program to meet that goal.

Result	Physique Rating	Explanation
1	Hidden obese	Small Frame Obese
		This person seems to have a healthy body type based on physical appearance; however, they have a high body fat % with low muscle mass level.
2	Obese	Medium Frame Obese
		This person has a high body fat percentage, with a moderate muscle mass level.
3	Solidly-built	Large Frame Obese
		This person has both a high body fat % and a high muscle mass.
4	Under exercised	Low Muscle & Average Body Fat%
		This person has an average body fat % and a less than average muscle mass level
5	Standard	Ave. Muscle & Ave. Body Fat %
		This person has average levels of both body fat and muscle mass.
6	Standard Muscular	High Muscle & Ave. Body Fat % (Athlete)
		This person has an average body fat % and higher than normal muscle mass level.
7	Thin	Low Muscle & Low Fat
		This person has both a lower than normal body fat % and muscle mass level.
8	Thin and muscular	Thin and muscular (Athlete)
		This person has lower than normal body fat % while having adequate muscle mass.
9	Very Muscular	Very Muscular (Athlete)
		This person has lower than normal body fat % while having above average muscle mass.

Source : Data from Columbia University (New York) & Tanita Institute (Tokyo)

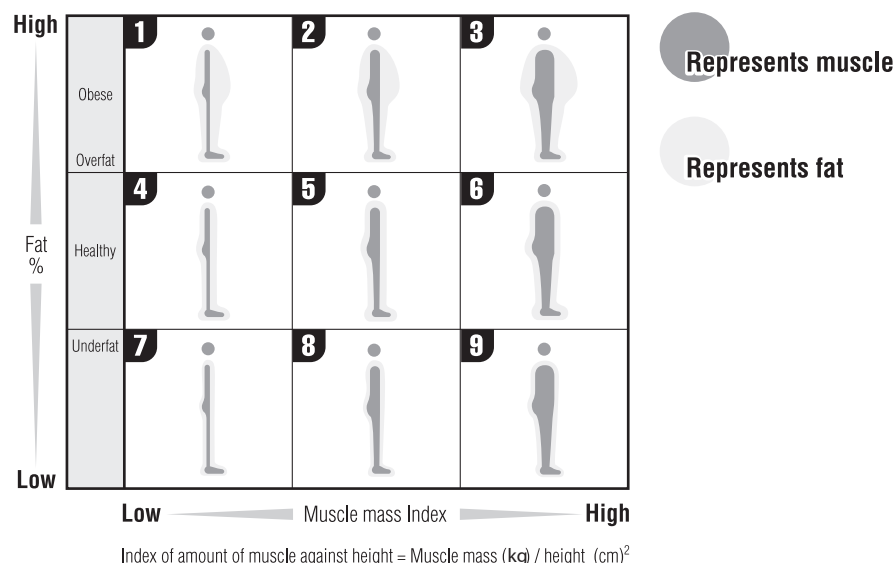

Various Criteria (continued)

en

How to Use

- What is bone mass? (Applicable age 18 to 99)

This feature indicates the amount of bone (bone mineral level, calcium or other minerals) in the body. Research has shown that exercise and the development of muscle tissue are related to stronger, healthier bones. While bone structure is unlikely to make noticeable changes in a short period, it is important that you develop and maintain healthy bones by having a balanced diet and plenty of exercise. People worried about bone disease should consult their physician. People who suffer from osteoporosis or low bone densities due to advanced age, young age, pregnancy, hormonal treatment or other causes, may not get accurate estimations of their bone mass.

Below is the result of estimated bone masses of persons aged 20 to 40, who are said to have the largest amounts of bone masses, by weight. (Source: Tanita Body Weight Science Institute)

Please use the below charts as a guide to compare your bone mass reading.

Women: Average of estimated bone mass

Weight (kg)		
Less than 50 kg	50 to 75 kg	75 kg and up
1.95 kg	2.40 kg	2.95 kg

Men: Average of estimated bone mass

Weight (kg)		
Less than 65 kg	65 to 95 kg	95 kg and up
2.66 kg	3.29 kg	3.69 kg

Note: Persons described below may obtain varying readings and should take the values given for reference purposes only.

- Elderly persons - Women during or after menopause
- People receiving hormone therapy

“Estimated bone mass” is a value estimated statistically based on its correlation with the fat-free mass (tissues other than the fat). “Estimated bone mass” does not give a direct judgment on the hardness or strength of the bones or the risks of bone fractures. If you have concerns over your bones, you are recommended to consult a specialist physician.

Output and Storage of Measurement Results

en

Data Output

Outputting measurement results via the USB or RS

The results are output to the PC immediately after measurement is completed.

Data is output in CSV format.

- USB connector (Type B 4 - pin female) and RS-232C are located on the back of the control box.
- Please provide your own cable as necessary as none are included.
USB cable: Type A 4 - pin (male) - Type B 4 - pin (male)
- Please install the necessary driver on your PC. Drivers can be downloaded from:
<http://www.tanita.eu>
- RS-232C and USB are mutually exclusive.

Data Storage

Data storage of measurement results

The results are saved to the SD card immediately after measurement is completed.

The  icon is displayed when a valid SD card is inserted.

A new file is created on the SD card for each day.

The file is created using the measurement date and time as the file name, as shown below.
“YYYYMMDD” (year, month and date)

If “error 12” is shown in the display, this indicates that there is not enough free space left on the SD card.

You can store approximately 10,000 measurement results (weight only mode) on a 2GB SD card.

- Do not remove the SD card when it is storing or reading data.
- Do not turn off the main power when the SD card is storing or reading data.

Output and Storage of Measurement Results (continued)

en

Printing Data

How to Use

Number	Items	Default
45	Fat Mass	1.on
46	Fat Free Mass	1.on
47	Muscle Mass	1.on
48	Total Body Water Mass	1.on
49	Bone Mass	1.on
50	Basal Metabolic Rate (BMR)	1.on
51	Metabolic Age	0.off
52	Visceral Fat Rating	1.on
54	BMI	1.on
56	Ideal Body Weight	0.off
57	Degree of Obesity	0.off
58	Desirable Range Fat % & Fat Mass	1.on
59	Total Body Water %	1.on
60	Graph Fat %	1.on
61	Graph BMI	1.on
62	Graph Visceral Fat Rating	1.on
63	Graph Muscle Mass	1.on
64	Graph BMR	1.on
66	Physique Rating	1.on
67	Bioelectrical data	1.on
68	TANITA Logo	1.on

Note 0: off, 1: on

Printing Measurement Results

The results are printed from the printer immediately after measurement is completed. The number of sheets that are printed is set in .

Lists of Contents of the Print Item Preset

Print item	Body composition analyzer						Scale
	Full			Short			
Body Type	Standard	Athletic	Child	Standard	Athletic	Child	
TANITA LOGO	✓	✓	✓	✓	✓	✓	✓
Category Name	✓	✓	✓	✓	✓	✓	✓
Model Number	✓	✓	✓	✓	✓	✓	✓
Date and Time	✓	✓	✓	✓	✓	✓	✓
ID No	*1	*1	*1	*1	*1	*1	*1
Body Type	✓	✓		✓	✓		
Gender	✓	✓	✓	✓	✓	✓	
Age	✓	✓	✓	✓	✓	✓	
Height	✓	✓	✓	✓	✓	✓	
Clothes Weight	✓	✓	✓	✓	✓	✓	✓
Weight	✓	✓	✓	✓	✓	✓	✓
Fat %	✓	✓	✓	✓	✓	✓	
Fat Mass	✓	✓	✓				
Fat Free Mass	✓	✓	✓				
Muscle Mass	✓	✓	✓				
Total Body Water Mass	✓	✓	✓				
Total Body Water %	✓	✓	✓				
Bone Mass	✓	✓					
Basal Metabolic Rate	✓	✓					
Metabolic Age	✓	✓					
Visceral Fat Rating	✓	✓					
BMI	✓	✓	✓	✓	✓	✓	
Ideal Body Weight	✓						
Degree of Obesity	✓						
Desirable Range	✓	✓	✓				
Target Fat %	*1	*1	*1	*1	*1	*1	
Indicator Fat %	✓	✓	✓				
Indicator BMI	✓	✓					
Indicator Visceral Fat Rating	✓	✓					
Indicator Muscle Mass	✓	✓					
Indicator BMR	✓	✓					
Physique Rating	✓	✓					
Bioelectrical Data	✓	✓	✓	✓	✓	✓	

See P.28 for an example of preset print.

*1: These items are not default.

In the Case to Select the Print Item Preset “Body Composition Analyzer - full - Standard”

Category name —

Weight —
• Measured weight.

Fat mass —
• Total weight of fat mass in the body.

Muscle mass —
• Bone-free lean tissue mass (LTM)

TBW % —

BMR* —
• Basal Metabolic Rate represents the total energy expended by the body to maintain normal functions at rest such as respiration and circulation.

Visceral fat rating* —
• Visceral fat rating feature indicates the rating of visceral fat.

Ideal body weight* —
• Ideal body weight is a value for which the BMI is 22.

Degree of obesity* —
• Calculated as (weight – Ideal body weight) / Ideal body weight × 100.

Bioelectrical data —
• The Resistance Reactance table indicates measurements for the impedance flow at each of the two dual frequency singals.

TANITA
BODY COMPOSITION ANALYZER DC-360
26/JAN/2015 20:59

INPUT
ID No. 0000001234567890
BODY TYPE STANDARD
GENDER MALE
AGE 35
HEIGHT 180 cm
CLOTHES WEIGHT 1.5kg

RESULT
WEIGHT 83.0kg
FAT % 25.9 %
FAT MASS 21.5kg
FFM 61.5kg
MUSCLE MASS 58.4kg
TBW 48.4kg
TBW % 58.3 %
BONE MASS 3.1kg
BMR 7588 kJ
1816kcal
METABOLIC AGE 50
VISCERAL FAT RATING 8
BMI 25.6
IDEAL BODY WEIGHT 71.3kg
DEGREE OF OBESITY 16.4 %

DESIRABLE RANGE
FAT % 8.0 - 19.9 %
FAT MASS 5.3 - 15.3kg

TARGET
TARGET BF% is: 15 %
Predicted weight: 72.4kg
Predicted fat mass: 10.9kg
FAT TO LOSE: 10.6kg
Consult your physician before beginning any weight management program. Tanita is not responsible for determining your target BF%.

INDICATOR
*FAT %
- | 0 | + | ++
*BMI
- | 0 | + | ++
*VISCERAL FAT RATING
| 13
*MUSCLE MASS
- | 0 | +
*BMR
- | 0 | +
*PHYSIQUE RATING
OBESE

*BIOELECTRICAL DATA
6.25kHz 50kHz
R 433.5 394.3
X -19.3 -29.0

ID
• When it is set with an ID, it is printed out. (The default is without an ID.)

Fat %
• Fat % is amount of body fat as a proportion of body weight.

FFM
• Fat Free Mass is comprised of muscle, bone, tissue, water, and all other fat free mass in the body.

TBW
• Total Body Water is the amount of water retained in the body. TBW is said to comprise between 50% to 70% of total body weight. Generally, men tend to have higher water weight than women due to a greater amount of muscle.

Bone mass*
• Bone mineral amount included in the entire bone.

Metabolic age*
• Metabolic age is evaluated young when a muscular amount is larger, and BMR is higher.

BMI
• Calculated with “weight (kg) / height(m)²”

The desirable range is for the Standard mode. In the case of the Athletic mode, the standard value is just a reference. And for those who are 17 years old or younger, only the body fat % is displayed as the standard value. The muscle mass, total body water and the estimated bone mass for those who are 17 years old or younger are for reference.

*18 to 99 yaers only

Please consult your doctor before you start a body weight management program. Tanita is not responsible for the target body fat ratio.

Reading Stored Measurement Result Data

- 1** Press the  key while the display is on, and select the setting 80.

Make sure the SD card is inserted.

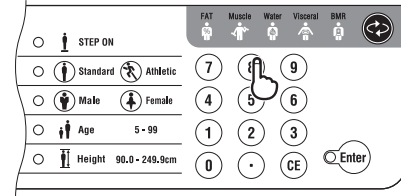

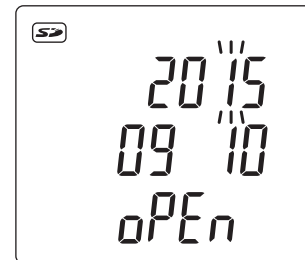

Enter the measurement date (YYYYMMDD) using the keypad, then press the Enter key and “oPEn” lights.

When there is no data matching with the entered date, “F-nonE” is displayed.

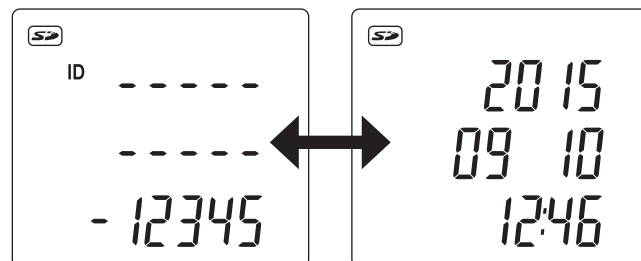

- 2** When a file is present, the ID and measurement date and time of the data saved at the beginning of the file are alternately displayed.



- (1) Press the  key, and the ID and measurement date and time of the data saved below are alternately displayed.
- (2) Press the Enter key, and Body weight, Pt (Clothes weight) and Body Fat % are displayed.

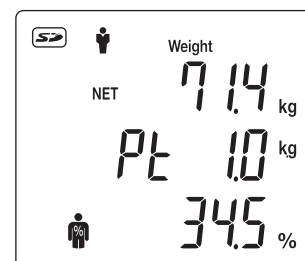

*Press the CE key to return to one higher level.

Output and Storage of Measurement Results (continued)

en

How to Use

General Instructions for Body Composition Measurement

Athletic Mode

- **Recommended for those who are 18 years or older and meet the following conditions.**
 - People who carry out 12 hours or more of cardiovascular exercise a week.
 - People who belong to a sport team or a sport organization with the aim of participation in competition, etc.
 - People who are professional athletes.

Target Body Fat

- **A target body fat % should be set by a professional only. Tanita is not responsible for setting the appropriate target body fat % for specific individuals.**

Attention

- **Posture when measuring**
 - Stand with both feet parallel on the electrodes.
 - Stand without bending knees.
- **The age input range is 5 to 99 years old.**
Input age 99 for those who are 100 years or older.

Note

- Inaccurate results may be reported after excessive food/fluid intake, or after periods of intense exercise.
- If clothes weight is input, clothes weight is subtracted from the weight measurements.

Troubleshooting

en

Please check the following before requesting repair.

	Problem	Solution
Measurement	Error with impedance measurement "Err40" is displayed.	<ul style="list-style-type: none"> • Stand barefoot on the platform for measurement. • If the soles of the feet are dry, use the included dropper to apply about 0.5 mL of water before measurement. • Check the input details.
	Error with zeroing "uuuuu" is displayed.	<ul style="list-style-type: none"> • Turn off the power and remove anything on the platform, then turn on the power and try measuring again.
	The weight value does not stabilize.	<ul style="list-style-type: none"> • Is the equipment placed on a vibrating surface? • Is the measuring platform tilted? • Is something blocking the gap in the measuring platform? • Remove any inserted objects.
Display	Nothing is displayed, even when the power is turned on.	<ul style="list-style-type: none"> • Confirm that the power is connected correctly.
	"-----" is displayed.	<ul style="list-style-type: none"> • The measured weight exceeds weighing capacity.
Printer	Run out of print paper "P-End" is displayed.	<ul style="list-style-type: none"> • Printer paper is not supplied. <ul style="list-style-type: none"> <input type="checkbox"/> Supply paper. <input type="checkbox"/> In the case that the printer is not used, press CE key and redo the initial setting.
	Printer cover open "COPEn" is displayed.	<ul style="list-style-type: none"> • The printer cover is open. <ul style="list-style-type: none"> <input type="checkbox"/> Properly close it. <input type="checkbox"/> Check that the printer paper is not slanted.
SD card	"Sd-F" is displayed.	<ul style="list-style-type: none"> • Insufficient space on the SD card. <ul style="list-style-type: none"> <input type="checkbox"/> Transfer or delete data from the SD card.
	"Sd-P" is displayed.	<ul style="list-style-type: none"> • SD memory card is write protected. <ul style="list-style-type: none"> <input type="checkbox"/> Remove (unlock) the SD card protection.
	"Sd-E" is displayed.	<ul style="list-style-type: none"> • SD Card malfunction. <ul style="list-style-type: none"> <input type="checkbox"/> Replace with a new SD card.

If Necessary

Technical Notes

en

Body composition measurement by the BIA method.

If Necessary

Introduction

This equipment provides estimated values for each measured value of body fat percentage, fat mass, fatfree mass, muscle mass and bone mass by the DXA method, estimated value for the total body water measured value by the dilution method and estimated value for the visceral fat rating by MRI method using the Bioelectrical Impedance Analysis (BIA method).

For measurement, a mode must be selected based on body type.

1) Standard (for 5 to 99 years of age)

2) Athletic (for Athletic persons who exercise considerably more than non-athlete)

Making a distinction by body type in the measurement mode produces more reliable body composition measurements for athletic persons, whose body compositions differ from those of average persons.

- Principles of body composition measurement

BIA is a means of measuring body composition – fat mass, predicted muscle mass, etc. – by measuring bioelectrical impedance in the body. Fat within the body allows almost no electricity to pass through, while electricity passes rather easily through water, much of which is found in muscles. The degree of difficulty with which electricity passes through a substance is known as the electrical resistance, and the percentage of fat and other body constituents can be inferred from measurements of this resistance.

The Tanita Body Composition Analyzer measures body composition using a constant current source with a high frequency current (6.25kHz, 50kHz, 90μA). The 4 electrodes are positioned so that electric current is supplied from the electrodes on the tips of the toes of both feet, and voltage is measured on the heel of both feet.

- What is the DXA method?

DXA was originally designed to measure bone mineral content, but in the full-body scan mode the body fat percentage, fat mass, and fat free mass of individual body parts (arms, legs, trunk) can also be measured. The image below shows one example of body composition measurement results obtained by DXA.

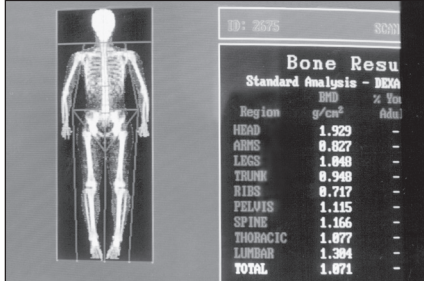

Bone Resu		
Standard Analysis - DXA		
Region	BMD g/cm ²	% Va Adul
HEAD	1.929	-
ARMS	0.827	-
LEGS	1.048	-
TRUNK	0.948	-
RIBS	0.717	-
PELVIS	1.115	-
SPINE	1.166	-
THORACIC	1.077	-
LUMBAR	1.304	-
TOTAL	1.071	-

Body composition measurement results obtained by DXA

- What is dilution method?

In the dilution method, a labeled substance for a known amount is given and the concentration in equilibrium diffusing evenly is measured to obtain the total amount of the solvent that dilutes the labeled substance.

To measure the total body water (TBW), deuterium oxide (D₂O) is generally used as the labeled substance. Deuterium oxide uses the overall total body water as dilution space so the total body water can be obtained. To obtain the extracellular fluid amount, sodium bromide (NaBr) is used as a labeled substance. Bromine (Br) is said to not enter the inside of cells, and uses extracellular fluid as the dilution space.

- What is the visceral fat?

Visceral Adipose Tissue (VAT) has been associated with increased risk of developing lifestyle-related diseases. Accordingly, knowing and periodically checking the estimated VAT accumulation serves as one factor of a number of factors in assessing the prevention of lifestyle related diseases.

Tanita has developed the technology for measuring the VAT accumulation risk through bioelectrical impedance analysis (BIA) in comparison with image analysis applied to magnetic resonance imaging (MRI), in addition to the established technology for measuring the percent of body fat. The VAT accumulation risk is calculated by estimating the VAT area by the BIA method on the basis of MRI image processing. This method has a higher correlation than the estimation of the VAT accumulation risk based on BMI or abdominal circumference (waist circumference), allowing estimation that corresponds more precisely to individuals.

*The VAT area by MRI is calculated by carrying out an image processing of the cross section of the lumbar vertebra L4-L5 regions.

If Necessary

(Fig. 1 - Fig. 3: Research results by N. Y. Columbia University and Jikei University Published by the North American Association for the Study of Obesity [NAASO] in 2004.)

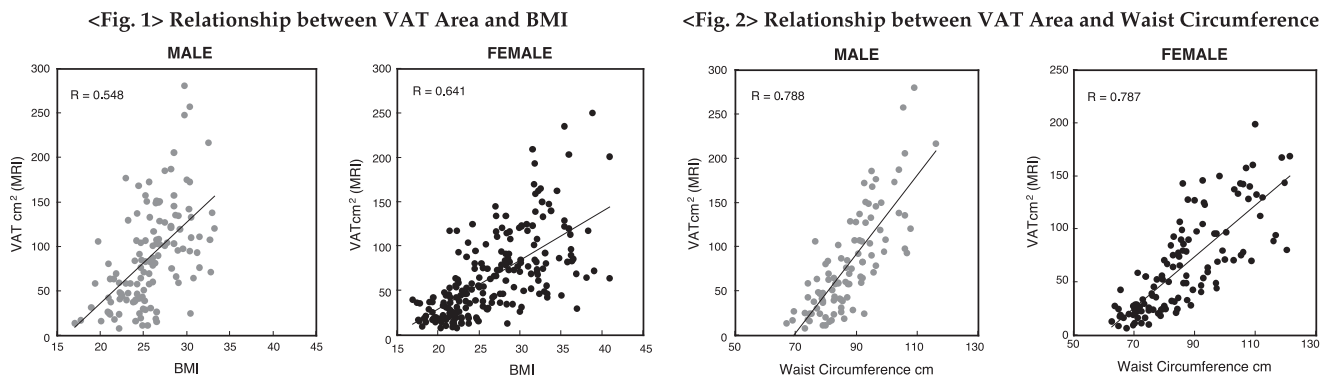

<Fig. 3> Relationship between VAT Area by MRI and Estimated VAT Area by Tanita's BIA

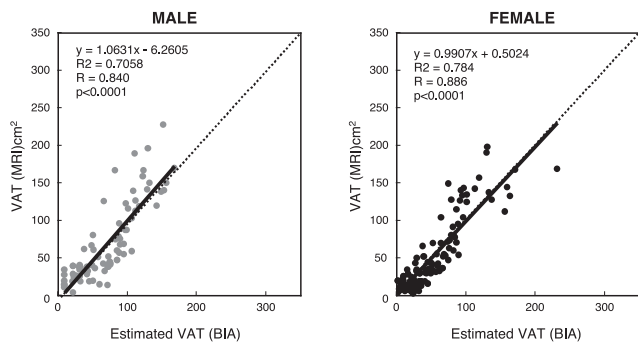

Technical Notes (continued)

en

- Factors giving errors in measurement

If Necessary

In the BIA method, impedance is measured and the body composition is calculated based on the value. It is known that impedance changes by the amount of the total body water that occupies about 60% of weight and the change in its distribution and temperature change. Therefore, for the purpose of research or for daily repeating of measurements, the measurement conditions must be kept constant. Measurement under the changing conditions of temperature and total body water distribution or blood flow volume of extremities due to exercising, taking a bath, etc., affects the measurement result since the electric resistance in the body also changes.

Therefore, it is recommended to measure under the following conditions for stable measurement.

- 1) 3 hours have passed after getting up and normal lifestyle activities are carried out during this period. (Bioelectrical impedance remains high if you remain sitting after getting up or drive a car, etc.)
- 2) 3 hours or more have passed after eating. (For 2 to 3 hours after eating, the impedance has a tendency to decrease.)
- 3) 12 hours or more have passed after vigorous exercise for measurement. (The tendency toward changes in impedance is not stable depending on the type and rigorousness of the exercise.)
- 4) If possible urinate before taking measurement.
- 5) For repeated measurements, measure at the same hour as much as possible. (At the same time of measurement of weight, the measurements can be made more stable by measuring at the same time of the day)

Very stable measured values can be obtained by measuring under the above conditions.

And in the development of this equipment, the following 6 items were set as conditions for the regression equation.

- 1) Prohibition of alcohol intake for 12 hours before measurement
- 2) Prohibition of excessive exercise for 12 hours before measurement.
- 3) Prohibition of excessive eating and drinking the day before measurement
- 4) Prohibition of eating and drinking for 3 hours before measurement
- 5) Urination just before measurement
- 6) Avoid measurements during menstruation (for female)

2) Inter-day changes

The diagrams below offer examples of actual measurements made of inter-day changes. A study was done to determine the degree of change in the impedance between the feet during dehydration; the first two days represent a normal daily routine, while in the latter two days a state of dehydration was induced using a sauna.

No significant inter-day change was measured in body weight, impedance between the feet, or body fat percentage during the normal daily routine. During the dehydrated state, however, a drop in body weight of 1kg was noted, with the impedance between the feet rising approximately 15Ω on the first day of dehydration and 30 to 35Ω on the second day. As a result, body fat percentage was up by around 1% on the first day of dehydration and by 1.5 to 2% on the second day.

As mentioned earlier, impedance increases when body weight is reduced (such as by dehydration), and decreases when body weight is increased through excess consumption of food and drink. The inter-day change in impedance is thus inversely proportional to the change in body weight.

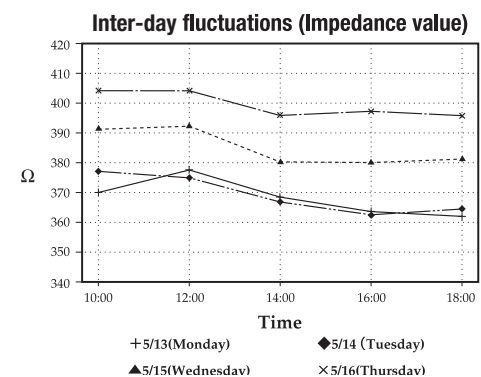
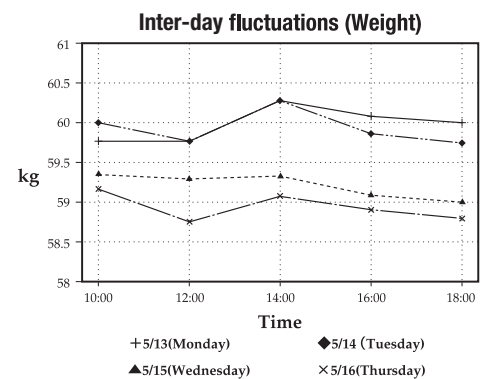

These inter-day changes stem from such causes as:

- 1) Temporary increases in body weight (total body water) through overeating and overdrinking
- 2) Dehydration due to heavy sweating during vigorous exercise
- 3) Dehydration due to alcohol consumption or the use of diuretics
- 4) Dehydration due to heavy sweating during saunas, etc.

Accordingly, it is recommended that instructions be provided to the subject to help eliminate these causes when accurate measurements are needed.

If Necessary

The Regression Formula for Basal Metabolic Rate (BMR)

en

If Necessary

The Basal Metabolic Rate (BMR) value is known to be closely related with the Fat Free Mass (FFM). It is also correlated with body weight, but there are issues when it is calculated from the body weight without considering body composition evaluation. This causes a greater error range to occur. In cases where people have the same body weight but different composition, values for obese people that have more body fat are overestimated, whereas those for muscular athletes are underestimated.

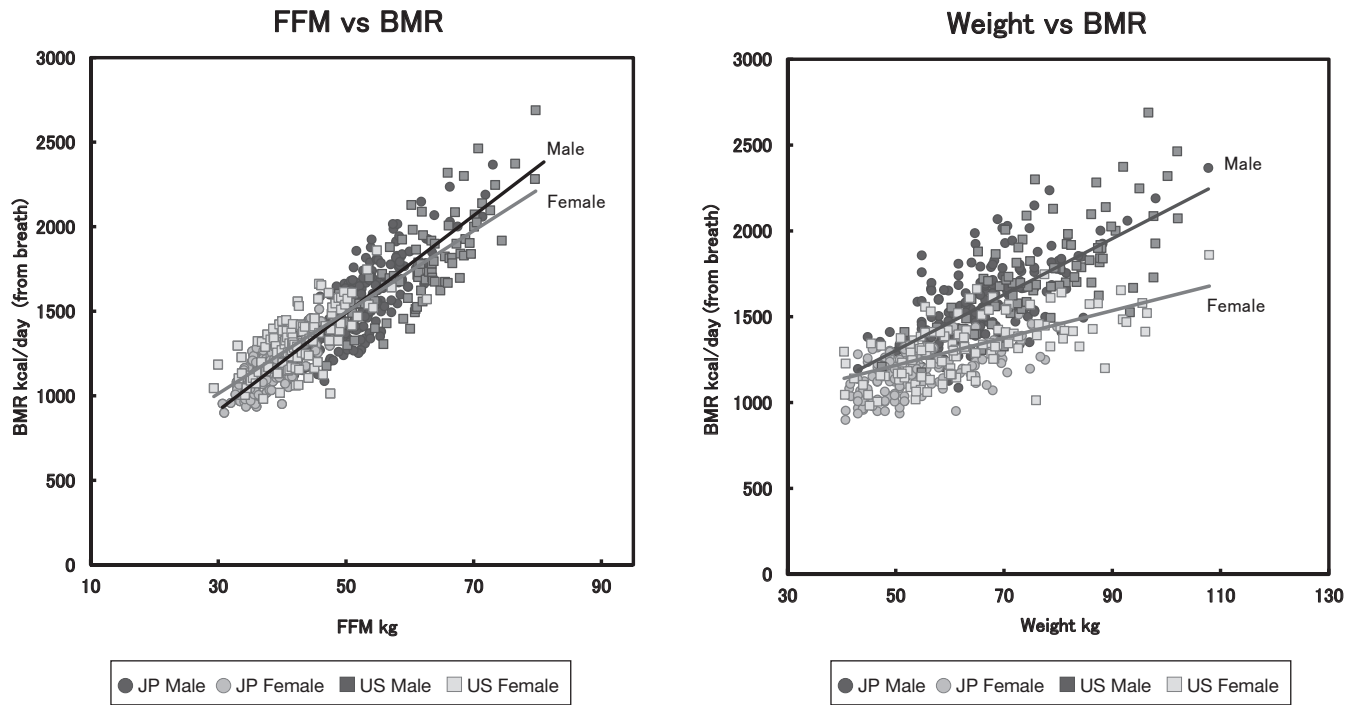

<Figure 1> Relationship of BMR from exhalation analysis with weight and FFM

Figure 1 shows that the correlation between BMR and FFM is far stronger than the correlation between BMR and weight.

The estimated regression equation for BMR developed through years of research by Tanita is extremely accurate because it reflects differences in individual body compositions and is calculated from the measured FFM. This estimated regression equation is based on the BMR measured using an exhalation analyzer, and has been checked for statistical validity.

These results were presented at the First Annual Nutrition Week (American College of Nutrition, American Society for Clinical Nutrition, American Society for Parenteral and Enteral Nutrition, North American Association for the Study of Obesity) held in 2002 in San Diego.

NOTE: This model has been calibrated for those between ages of 18 to 84. Those individuals outside of this age range may not obtain accurate readings.

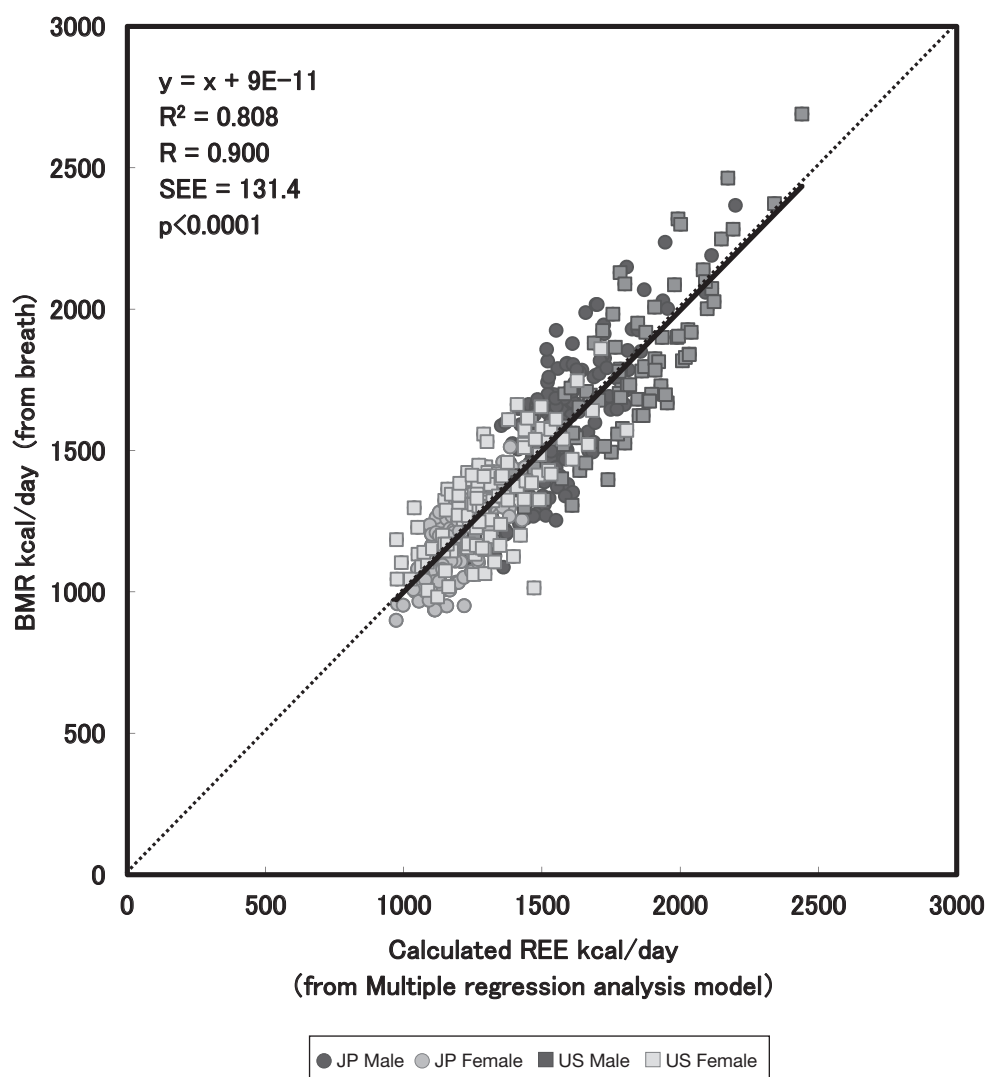

<Figure 2> Relationship of BMR and calculated REE from Tanita multiple regression analysis model
 Modified based on data announced at Nutrition Week held in San Diego in 2002)

Specifications

en

If Necessary

Model Number		DC-360
Power Source		AC adapter Input:100 – 240V Output:12V
Electric Current Range		25VA
Impedance Measurement	Measurement System	Dual-frequency 4 electrode
	Measurement Frequency	6.25kHz / 50kHz
	Electrode Materials	Stainless steel
	Measurement Part	Between both feet
	Measurement Range	150.0 to 1,000.0Ω (0.1Ω increments)
	Accuracy at First Calibration	±2%
Weight Measurement	Measurement System	Strain gauge load cell
	Range	2 to 270kg (including preset tare value)
	Minimum Graduation	0.1kg
	Accuracy at First Calibration	±0.2kg
Display		LCD screen
Interface		USB 2.0 (Type B connector)
		RS-232C
		SD card
Usage Conditions Range	Temperature	5 to 35°C
	Relative Humidity	30 to 80% (non-condensing)
Storage Conditions Range	Temperature	-10 to 60°C
	Relative Humidity	10 to 90% (non-condensing)
Product Weight	Remote Display Version	8.3kg
	Column Mounted Version	11.2kg
Product Size	Platform	395mm x 390mm x 67mm
	Height (Column Mounted Version)	1027mm

Input Items	Clothes Weight	0.0 to 10.0kg (0.1kg increments)
	ID No.	16 digits
	Gender	Female / Male
	Body Type	Standard / Athletic * ¹
	Age	5 to 99 years
	Height	90.0 to 249.9cm (0.1cm increments)
	Target Body Fat %	4 to 55% (1% increments)
Output Items	ID No.	16 digits
	Gender	Female / Male
	Body Type	Standard / Athletic * ¹
	Age	5 to 99 years
	Height	90.0 to 249.9cm (0.1cm increments)
	Clothes Weight	0.0 to 10.0kg (0.1kg increments)
	Weight	2.0 to 270.0kg (0.1kg increments)
	Fat %	3.0 to 75.0% (0.1% increments)
	Fat Mass	0.1kg increments
	FFM	0.1kg increments
	Muscle Mass	0.1kg increments
	BMI	0.1 increments
	Bone Mass *²	0.1kg increments
	Metabolic Age*²	1 year increments
	Basal Metabolic Rate *²	1kcal / 1kJ increments
	Visceral Fat Rating *²	1 to 59 (1 increments)
	TBW	0.1kg increments
TBW %	0.1% increments	
Physique Rating *²	9 ratings	
Bioelectrical Data	Resistance / Reactance	

*¹ Athletic mode can be selected only 18 to 99 years old

*² 18 to 99 years old

The product design and specifications may be changed at any time without prior notice.



This device meets the EMC Directive 2004/108/EC and the RoHS Directive 2011/65/EU.

Disposal



This equipment is an electronic device. Please dispose of this equipment appropriately, not as general household waste. Be sure to follow the regulations in your area when disposing of this equipment.

<EU representative>

TANITA® Europe B.V.

Hoogoorddreef 56-E, 1101 BE Amsterdam, the Netherlands TEL: +31-20-560-2970 FAX: +31-20-560-2988 www.tanita.eu

<Manufacturer>

TANITA® Corporation

1-14-2, Maeno-cho, Itabashi-ku, Tokyo 174-8630, Japan TEL: +81 (0) 3-3968-7048 FAX: +81 (0) 3-3968-2661 www.tanita.co.jp

TANITA Corporation of America, Inc.

2625 South Clearbrook Drive,
Arlington Heights, Illinois 60005, U.S.A.
TEL: 1-847-640-9241
FAX: 1-847-640-9261
www.tanita.com

TANITA Health Equipment H.K.LTD.

Unit 301-303, Wing On Plaza, 3/F., 62 Mody Road,
Tsimshatsui East, Kowloon, Hong Kong
TEL: +852-2834-3917
FAX: +852-2838-8667
www.tanita.asia

TANITA India Private Limited

A-502, Mittal Commercial, Off. M.V. Road (Andheri Kurla Road),
Marol, Andheri-East, Mumbai 400 059 INDIA
TEL: +91-22-3192-6107
FAX: +91-22-2859-9143
www.tanita.co.in

TANITA (Shanghai) Trading Co., Ltd.

Room 8005, 877 Huai Hai Zhong Lu, Shanghai,
The People's Republic of China
TEL: +86-21-6474-6803
FAX: +86-21-6474-7901
www.tanita.com.cn